



**BERTRAND  
PUMA**

La griffe boulangère

# RD2 range Dividers-Rounders



DIVIDERS  
ROUNDERS



# TECHNICAL INFORMATION

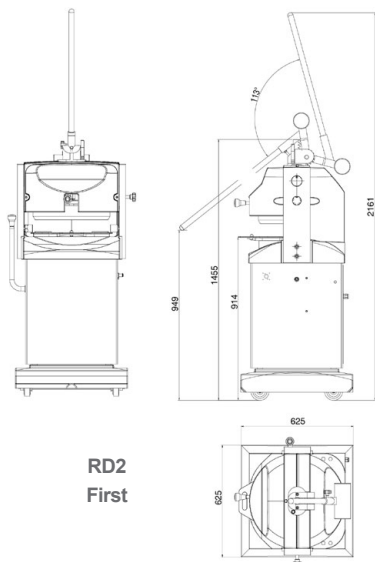

**RD2  
First**

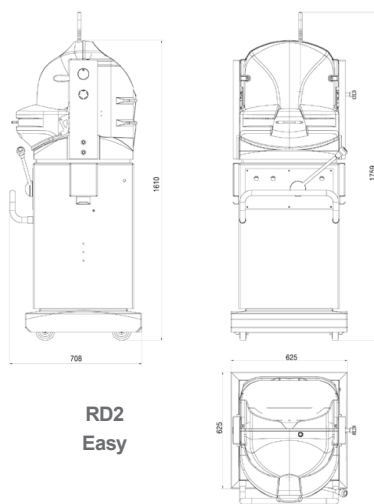

**RD2  
Easy**

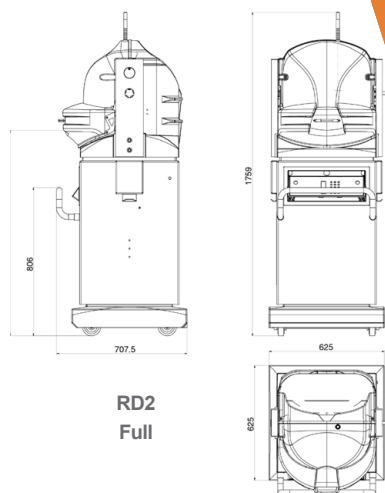

**RD2  
Full**

RD2 14/4 RD2 30/3 RD2 30/4 RD2 36/4 RD2 52/3

Electric supply	400V / TRI+N+T / 50-60Hz				
Power (kW)	First	0,55			
	Easy	1,3			
	Full	1,3			
Rated current (A)	First	2			
	Easy	4			
	Full	4			
Number of divisions	14	30	30	36	52
Maximum capacity of the tank (kg)	4	3	4	4	3
Minimum dough pieces weight (g)	85	30	40	30	20
Maximum dough pieces weight (g)	260	86	122	101	50
Width (mm)	625				
Depth (mm)	625				
Height - opened cover (mm)	First	1455			
	Easy	1610			
	Full	1610			
Working height (mm)	First	914			
	Easy	1120			
	Full	1120			
Maximum overall width (mm)	625				
Maximum overall depth (mm)	625				
Maximum overall height (mm)	First	2161			
	Easy	1759			
	Full	1759			
Weight (kg)	First	400			
	Easy	400			
	Full	410			

## CHARACTERISTICS

Using a divider rounder allows dividing the dough in equal dough pieces and rounding them for making buns.

These are equipped with wheels for easy mobility and that retract during the use of the machine. Maintenance is simple through easy access to components. Moreover, the separation disc can be easily tilted forward.

The Teflon coating on that same disc allows quick and easy cleaning.

## CONSTRUCTION

Structure made of epoxy painted steel, on casters.

- Controls are brought together for easier use.
- Easily interchangeable dividing head.
- On the *First* models, the putting under pressure and cutting are made by upper lever and the rounding by lateral lever.
- On the *Easy* models, the putting under pressure and cutting are automatic and the rounding is done using a front lever.
- On the *Full* models, the putting under pressure and cutting are programmed.
- Each machine is delivered with 3 rounding plates with tracks corresponding to the number of divisions of the machine.
- Engine protected by a thermal-magnetic circuit breaker.



BPJ - 01/2018  
Pictures and illustrations are not contractually binding

BP 54 - Rue Benoît Frachon - F-26802 Portes-Les-Valence Cedex - Tél. +33 (0)475 575 500 - Fax +33 (0)475 572 319  
contact@bertrand-puma.fr - www.bertrand-puma.fr

an Ali Group Company



The Spirit of Excellence